

RH-DX620D

Cobweb Antenna

6, 10, 12, 15, 17 and 20m band (twin wire)

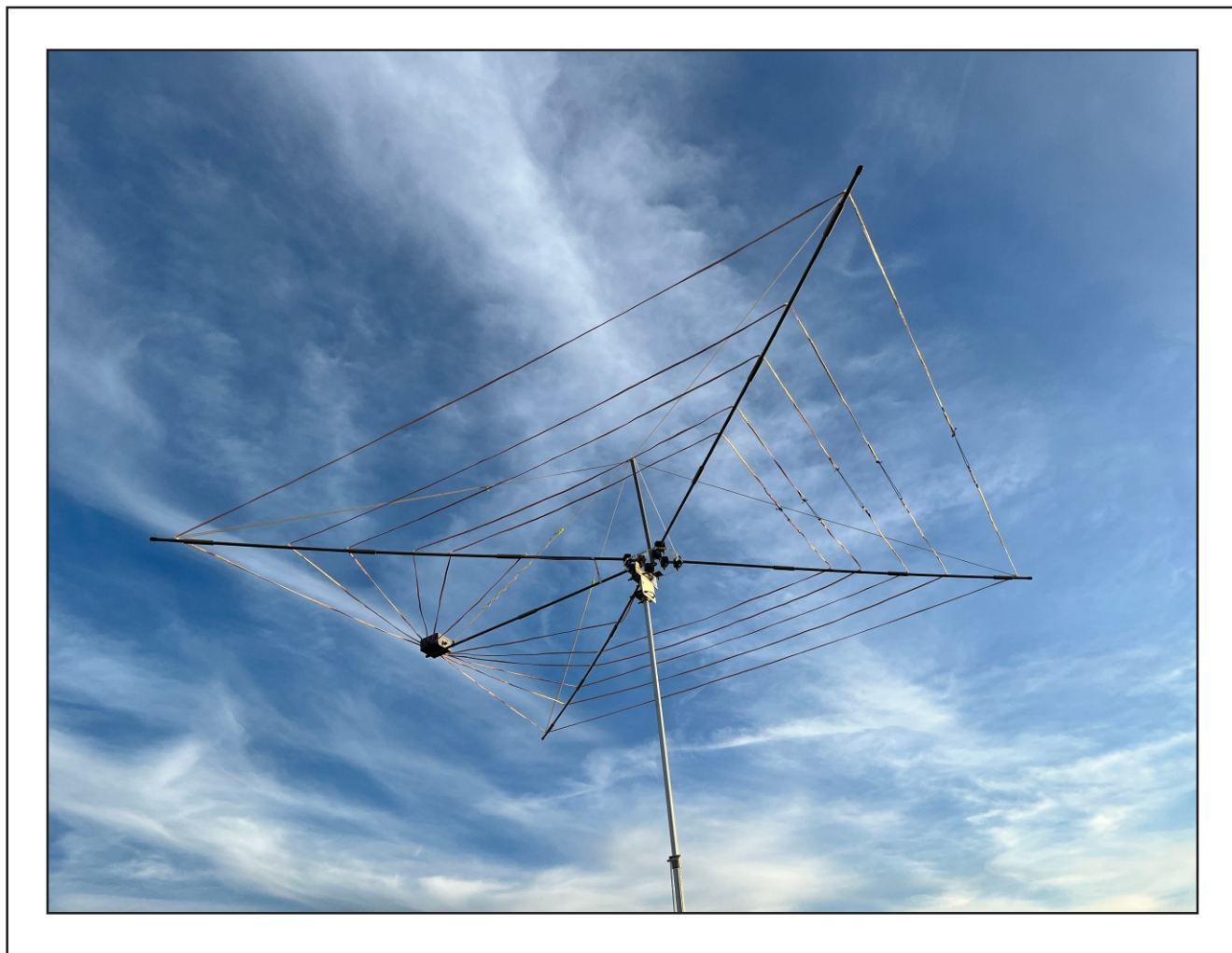

Instruction Manual

Read all instructions before operating

RADIOHAUS
www.radiohausamerica.com



THANK YOU!

Thank you for your purchase! This portable or base use Cobweb antenna can be used for the 6, 10, 12, 15, 17 and 20 meter amateur radio bands. This antenna was developed considering its efficiency and durability of the materials. It is ideal for Ham Radio operators with limited space. It's great for using in portable operation.

MAIN SPECIFICATIONS

The main advantages of the RH-DX620D antenna are that it is small, lightweight, made of fiberglass and requires a single support to be installed.

This antenna produces a pure horizontally polarised signal with a confined electric field. This results in much reduced coupling to nearby conductors, so that losses and interference problems are reduced.

Other great features:

- ☞ HOA friendly
- ☞ Portable
- ☞ Great for field day
- ☞ Super light
- ☞ Foldable
- ☞ Made of fiberglass, acrylic and stainless steel
- ☞ Omni-directional (Do not need a rotator)
- ☞ Works from 10' (3 meter) above ground
- ☞ Easy assembling
- ☞ Minimum EMC issues
- ☞ Low SWR
- ☞ 50 Ohm feed
- ☞ 300 Watt maximum power
- ☞ 6 to 20m band operation
- ☞ Great for QRP operation
- ☞ Twin Cable
- ☞ Made in the USA

ATTENTION



- ☞ Do not handle or install this antenna near power lines
- ☞ Always use protective equipment for installation
- ☞ Do not touch the antenna when the radio is transmitting
- ☞ Wear gloves to handle fiber tubes, since small particles can cause skin irritation

TOOLS & ACCESSORIES REQUIRED (not supplied)



- ☞ Small pliers
- ☞ Wrenches
- ☞ Silicone sealant
- ☞ 50 Ohm coaxial cable
- ☞ Mast, tripod, mounting hardware

IDENTIFICATION OF THE PARTS OF YOUR ANTENNA

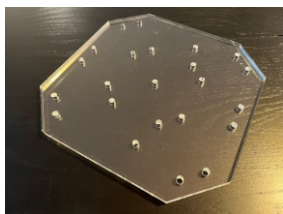

1 Acrylic mounting plate



- 18 units - M6 x 45mm (0.24 x 1.77") Cap head screws
- 2 units - M5 x 20mm (0,19 x 0.79") Hexagon Bolts
- 18 units - M6 Hexagon nuts
- 2 units - M5 Hexagon nuts
- 18 units - M6 Lock washers
- 4 units - M5 Flat washers
- 2 units - M5 Lock washers



4 Foldable element arms



9 pairs - 1/2" Pipe clamps



1 Mounting bracket kit



1 Foldable junction box arm with antenna elements



1 Support tube

Miscellaneous:

- 25 units - UV Nylon cable ties
- 3m (10 ft.) - Guy line rope (to separate and isolate each band elements)
- 3 units - White support rope (2 longer and 1 shorter)
- 15 units - #3 Rubber bands
- 3 units - Rope stretcher

ASSEMBLY - Mounting plate

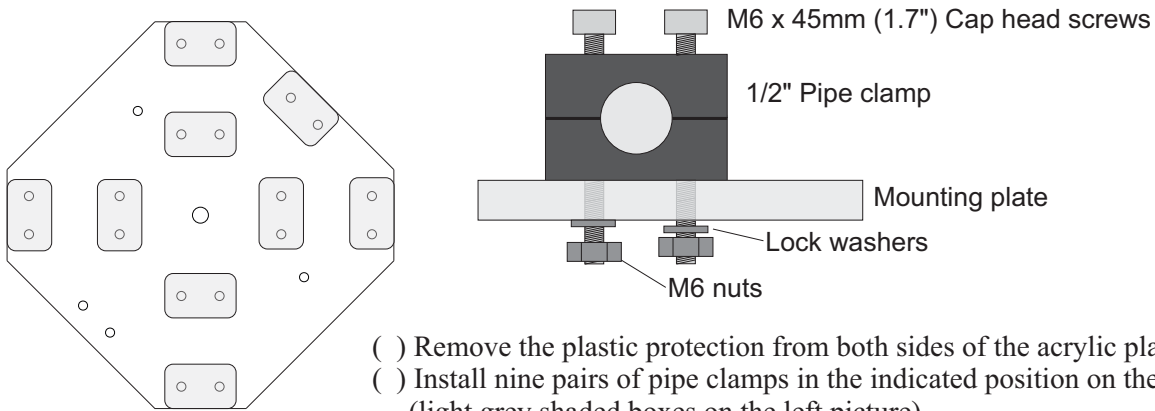

- () Remove the plastic protection from both sides of the acrylic plate
- () Install nine pairs of pipe clamps in the indicated position on the mounting plate (light grey shaded boxes on the left picture)
- () Use M6 x 45mm screws, lock washers and nuts
- () Do not tighten at this time. Insert the nuts to hold the washers in place

ASSEMBLY - Element arms

- () Unfold the four element arms on a flat surface like a garage floor or over grass
- () Note that each element has a longer tube in one side
(illustrative figure)

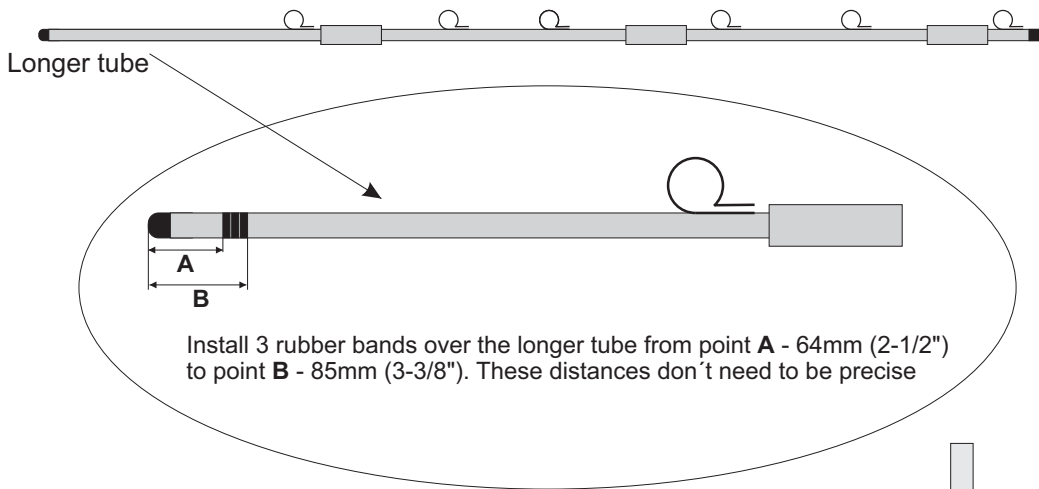

- () Insert the long end of the tube in the indicated position in the mounting plate (4x)
- () Use an allen hex wrench to firmly tighten the 16 screws

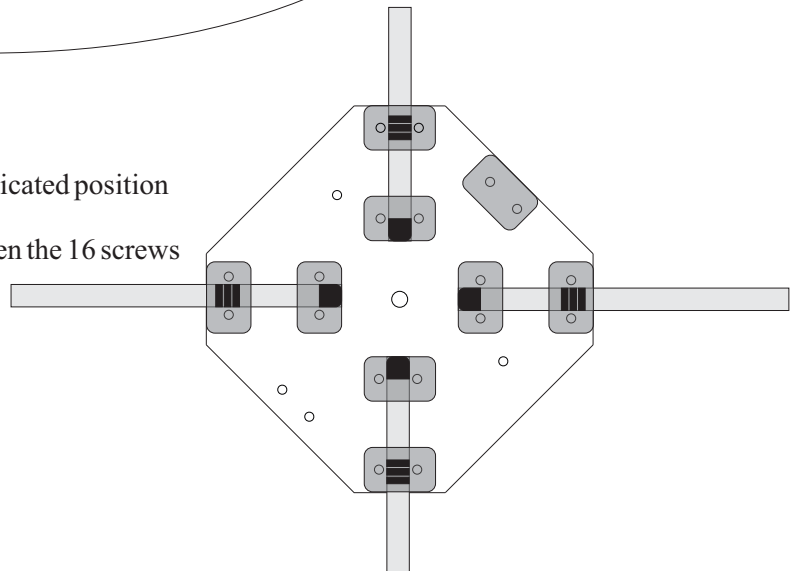

ASSEMBLY - Element arms (continue)

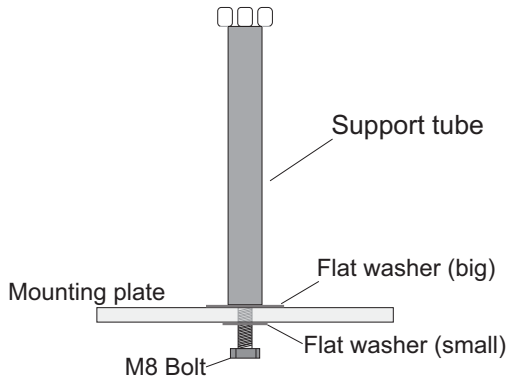

- () Remove the M8 screw from the support tube
- () Install the tube at the central hole of the mounting plate
- () Firmly tighten the screw into the tube

- () Identify the longer white rope (3 were provided - 2 longer, 1 shorter)
- () Tie a knot in the outermost nylon clamp (1)
- () Insert the rope through one of the nylon clamps on top of the support tube (A and 2 on images below)
- () Pass the rope through the stretcher (3 - picture)
- () Pass the rope through the other outermost nylon clamp (4)
- () After passing through clamp 4, tie a knot (5)
- () Repeat previous steps to the perpendicular arms
- () Do not add tension to the stretcher at this time

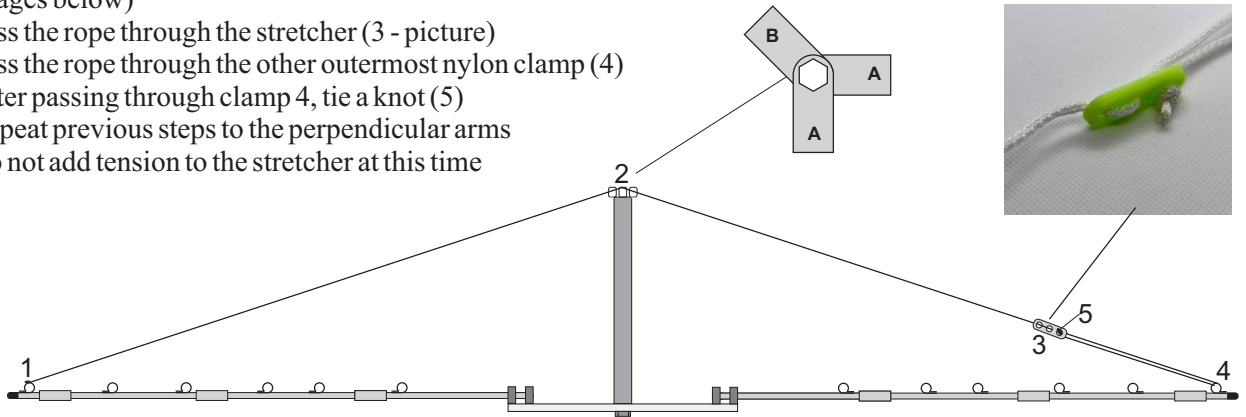

ASSEMBLY - Antenna on a mast

- () Mount the two U-bolt clamps into the stainless steel bracket (picture)
- () Position the bracket to match the holes in the middle of the mounting plate
- () Insert in the two indicated holes the M5 Hexagon bolts, flat washers, lock washer and a nut and firmly tighten
- () Use the two U-bolts to secure the bracket to a mast (1-1/4 to 2-1/4 in diameter)

Use 1 1/4 to 2 1/4 tube mast

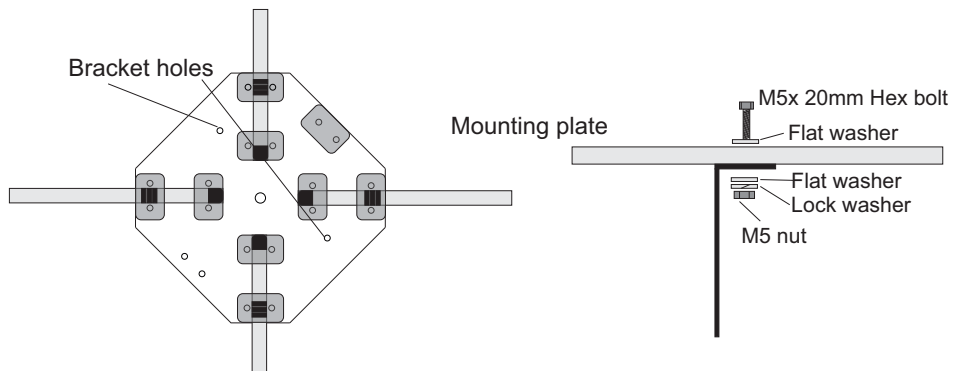

ASSEMBLY - Junction Box Arm

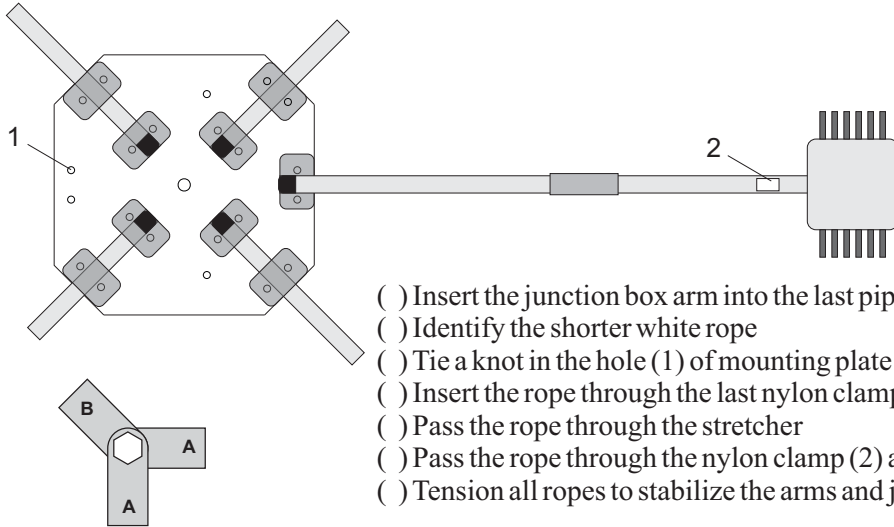

- () Insert the junction box arm into the last pipe clamp and firmly tighten the screws
- () Identify the shorter white rope
- () Tie a knot in the hole (1) of mounting plate
- () Insert the rope through the last nylon clamp on top of the support tube (B)
- () Pass the rope through the stretcher
- () Pass the rope through the nylon clamp (2) and then tie a knot in the stretcher
- () Tension all ropes to stabilize the arms and junction box

ASSEMBLY - Antenna elements

- () Start with the 6m band (the shorter wire). Pass both sides thru the clamps and use a nylon cable tie to fasten the wire about 11" (279mm) from the nylon clamp.
- () Leave some wire hanging off
- () Pass the 10, 12, 15, 17 and 20 m bands thru respective nylon clamps
- () Refer to the **frequency table** to bend the wires
- () Use adhesive tape to secure the wires together
- () After final adjustment, use the cable ties
- () Use the guy line rope to tie the ends of each antenna element

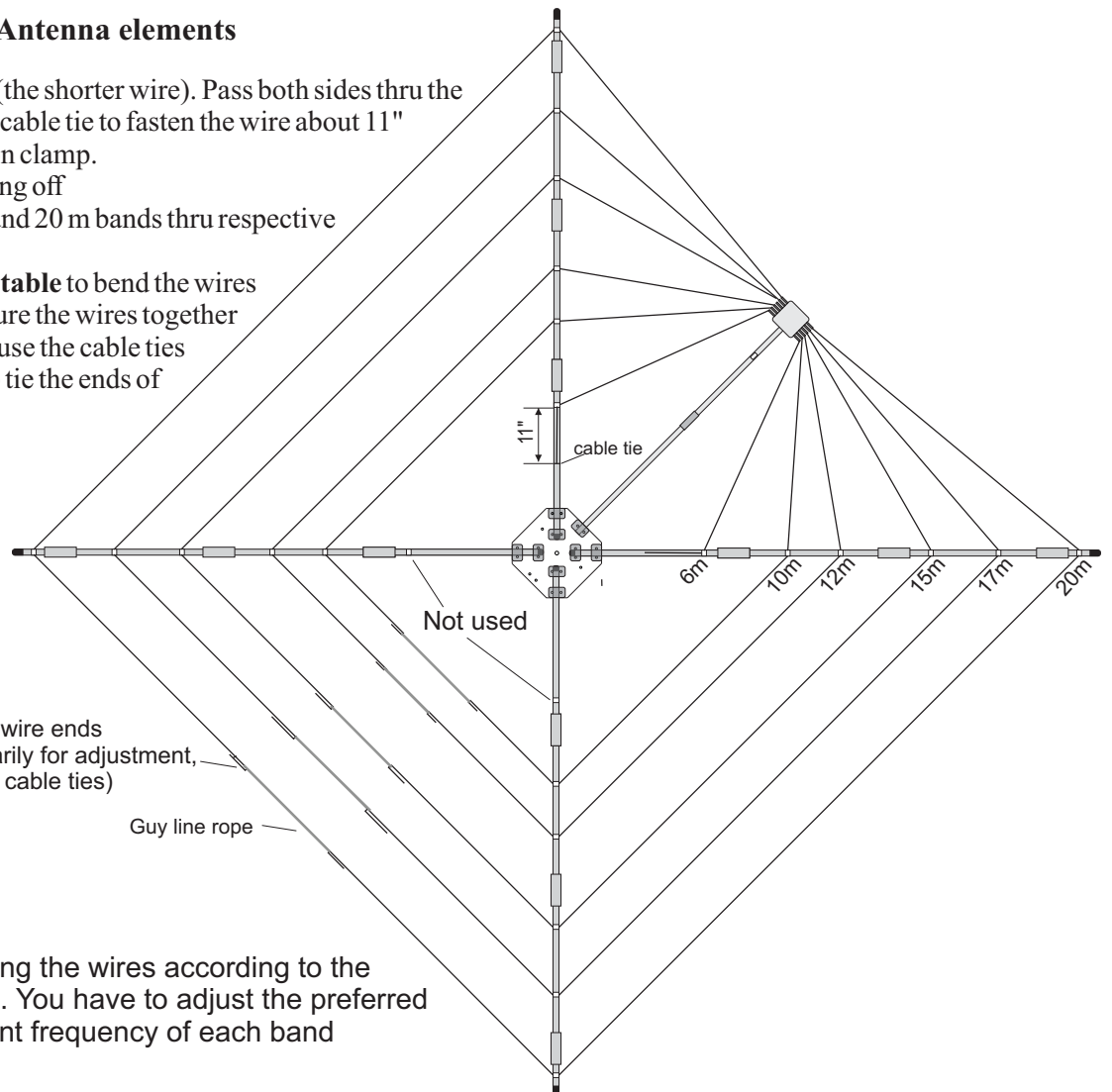

Start bending the wires according to the frequency table. You have to adjust the preferred resonant frequency of each band

ADJUSTMENT

Adjusting your Cobweb Antenna RH-DX620D is a process that requires patience and time in order to get the best performance.

During testing and development of this product, we were rewarded with many QSO's and DX on all bands with the antenna installed just 2.1 meters (7 feet) above ground with a QRP (5W) transceiver.

To adjust your new antenna, remember this basic rule: **to lower the resonant frequency, increase the length. To increase the frequency, decrease length.**

- () When raising the antenna make sure it is not too close to obstacles such as trees, walls or fences. 2 m (6.5') clearing from obstacles is ideal to improve performance.
- () Using an antenna analyzer is ideal to make frequency adjustments. If an analyzer is not available, use a transceiver with power reduced to 5W.

This antenna has limited bandwidth with an acceptable SWR. Thus, it is important that you define which is the preferred segment of operation in each band and try to leave each band adjusted to your preference.

The table below shows how many mm (or inches) the ends of each wire need to be bend for the respective frequencies. **Remember that it's just a reference to start adjusting your antenna.**

Frequency table

BAND	BEND (mm)	BEND (inches)	Freq. min. SWR*
6m	hanging off	hanging off	52,000 kHz
10m	170	6.7	28,050 kHz
12m	75	3.0	24,900 kHz
15m	80	3.2	21,040 kHz
17m	140	5.5	18,100 kHz
20m	203	8.0	14,160 kHz

*Results obtained in the prototype



- () Connect a 50 Ohm coaxial cable and protect the connector with silicone sealant (not supplied)
- () Bend both sides of antenna element with the same length
- () Fasten the wire and the "bend" together. Use adhesive tape to temporarily fasten it
- () Measure the resonant frequency
- () Increase or decrease the length to preferred resonant frequency
- () When you get the ideal frequency, use the supplied cable ties to fasten the wires
- () Repeat these steps for each band from 6 to 20m
- () Raise the antenna to a minimum of 7 ft (2.1m). The performance is better if you raise more than this height.

GOOD DX's!

**Feel free to contact us in case of any comments or questions.
Enjoy your new Cobweb Antenna RH-DX620D!**

Designed and made in USA by

RADIOHAUS

www.radiohausamerica.com
sales@radiohausamerica.com